



Prescriptive Program Rebate Application

Check the appropriate program box for your rebate.

- Cooling
 FSO (Fluid System Optimization)
 Foodservice Equipment
 Heating
 Lighting
 Motors and Drives
Variable frequency drives (VFD)

OID _____
Internal use only

Customer information

Xcel Energy premises numbers: Electric _____ and/or Gas _____

Company name _____ Date submitted _____

Installation address _____ City _____ State _____ ZIP _____

Mailing address _____ City _____ State _____ ZIP _____
(For rebate if different from installation address)

Contact name (print) _____ Phone _____

Contact email _____ Fax _____

Equipment location description (required) _____

Total project cost: \$ _____
(Acceptable expenses include equipment and labor and do not include tax, freight or shipping costs.)

Customer signature _____ Date _____

This signature is required from the individual tied to the Xcel Energy premises number herein. By signing here, I acknowledge the information in this application is accurate and complete. I confirm I have read, agree with and understand the terms and conditions on page 2 of this application. I also authorize Xcel Energy to provide a copy of the project preapproval notification to the equipment supplier or vendor so as to expedite the project process.

Alternative rebate recipient

Complete this section only if the customer wants the rebate check to go to someone other than the customer contact tied to the premises number above.

Company name _____ Contact name _____

Address _____ Phone _____

City _____ State _____ ZIP _____

I authorize the above company to receive the rebate check for this project.

Customer signature _____ Date _____

Xcel Energy account representative name _____ Signature _____

Trade partner information (vendor/contractor information)

Company Name _____ Trade Partner ID# _____

Contact Name (print) _____

Address _____ City _____ State _____ ZIP _____

Contact email _____ Phone _____

*By providing your email address, you are granting Xcel Energy permission to send updates or questions via email regarding this project as well as future emails regarding our programs and services.

Prescriptive program rules and requirements

Qualifying customers

Xcel Energy prescriptive rebate programs are available to Xcel Energy business electric and/or gas customers that install qualifying equipment in Xcel Energy's Minnesota service territory.

How to apply for rebates

1. Fill out the rebate application (for each installation address.)
2. Attach a copy of the paid, itemized invoice(s). Be sure that the quantity, make, model number and unit price of each item appears on the invoice.
3. Make a copy of this document for your records.
4. If you have questions please contact your Xcel Energy account manager or one of our energy efficiency specialists to discuss and/or complete the project application form.
5. You can email your completed project paperwork to: energyefficiency@xcelenergy.com, fax to: 800.311.0050, or mail to: Energy Efficiency Specialist, Business Solutions Center, P.O. Box 8, Eau Claire, WI 54702-0008.
6. Once completed paperwork is submitted, rebate payments are usually made in six to eight weeks after the rebate application has been processed.

Custom Efficiency rebate program

Equipment that is not eligible for prescriptive rebates can be submitted through the Custom Efficiency program. **Preapproval through the Custom Efficiency program is required before the purchase and installation of equipment.**

The Custom Efficiency rebate application and program details can be found at xcelenergy.com/CustomEfficiency.

Rules and requirements

- All equipment must be new. Used or rebuilt equipment is not eligible for a rebate.
- Equipment must meet program specification requirements and be purchased, installed and operating prior to submitting an application for a rebate. Xcel Energy reserves the right to withhold payment for products that do not meet the requirements.
- Rebates cannot exceed 60 percent of the project cost (including equipment and labor).
- A signed application and detailed installation invoice(s) must be completed and submitted to Xcel Energy within 12 months (24 months for motors, VFDs and constant speed motor projects) of the invoice date.
- Xcel Energy is not responsible for any lost, late, stolen, ineligible, illegible, misdirected or postage-due mail.

- All completed submissions become the property of Xcel Energy upon receipt and will not be returned.
- Xcel Energy will issue a rebate in the form of a check.
- Xcel Energy reserves the right to conduct a random on-site inspection of your project before or after issuing a rebate. The customer agrees to provide reasonable access to inspect the installation. On-site inspections may be performed up to one year after the date the rebate check is issued. If Xcel Energy finds that the application does not comply with Xcel Energy rules and qualifications, any rebate amount may be adjusted, denied or subject to return.
- Program rules, requirements and offer are subject to changes at any time. Xcel Energy's prescriptive rebate programs are subject to 60 days notice of cancellation. Changes or notifications will be posted at xcelenergy.com/Rebates. The customer and trade partner are responsible for contacting an energy efficiency specialist to determine whether the program is still in effect and to verify program parameters. Call 855.839.8862 or email energyefficiency@xcelenergy.com.
- Xcel Energy reserves the right to refuse payment and participation if the customer or contractor violates program rules and procedures, or local, state or federal regulations. Xcel Energy is not liable for rebates promised to customers as a result of misrepresentation of the program.
- Xcel Energy's acceptance of the application does not guarantee payment of rebate.
- Xcel Energy retains the right to limit rebates or to make adjustments to correct incentive calculations if necessary. Energy savings calculations are estimates and may vary from actual results.

Warranty information

- Xcel Energy does not endorse any particular manufacturer, product or system design by offering these rebates.
- Xcel Energy will not be responsible for any tax liability imposed on the customer as a result of the payment of rebates; does not expressly or implicitly warrant the performance of installed equipment (contact your contractor for detailed equipment warranties).
- Xcel Energy is not responsible for the proper disposal/recycling of any waste generated as a result of this project; is not liable for any damage caused by the operation or malfunction of the installed equipment; and does not guarantee that a specific level of energy or cost savings will result from the implementation of energy conservation measures or the use of products funded under these programs.

Drive rebate rules and regulations

Qualifying customers:

The Motor and Drive Efficiency program is available to Xcel Energy electric retail rate business customers in Minnesota who purchase and install HVAC, non-HVAC and Water Well Pump VFDs (variable frequency or adjustable speed) drives to control their end use equipment/systems. It offers prescriptive and custom rebates depending on your equipment and situation.

Rebates for motors are available and use a different and separate application.

Prescriptive HVAC and non-HVAC VFDs

- Installations must meet one of the equipment/situation combinations listed in the requirements rebate chart below to qualify as prescriptive.
- Installed on single stage centrifugal fan and pump systems from 1 hp to 200 hp.
- Variable/Adjustable Speed Drive controls of a specific motor system can be sized differently when compared to the motor it is controlling.

Requirements for prescriptive HVAC and non-HVAC VFD rebates			
For these systems	...controlled equipment must be	...in these situations.	
HVAC systems (Non-new construction)	Fans/blowers (centrifugal or axial)	Retrofit or failed-VFD-replacement	
	Single-stage centrifugal pumps	Closed-loop systems, evaporative condenser, cooling tower spray/circulating pumps	Retrofit or failed-VFD-replacement
HVAC systems (New construction buildings)	Fans/blowers (centrifugal or axial)	Must be ≤ 7.5 hp	
	Single-stage centrifugal pumps	Closed-loop systems, evaporative condenser, cooling tower spray/circulating pumps	Must be ≤ 50 hp
Non-HVAC systems	Fans/blowers (centrifugal or axial)	Retrofit and replacing failed VFDs	
	Single-stage centrifugal pumps	Retrofit and replacing failed VFDs	

The drive rebate is calculated using the lowest rating of either the drive nameplate or the motor nameplate. If you don't know the RPM or the enclosure of the motor that the VFD is controlling see page 4 for additional information.

The drive system must be automatically controlled to vary the motor's speed to match changes in the system's load, rather than by manual means.

For new construction projects:

- Drives used for heat rejection equipment or variable air volume systems greater or equal to 7.5 hp do not qualify.

Note: This is required because the code only excludes these types, there are many other types that have no such limitations.

- Drives used for hydronic pump systems greater or equal to 50 hp do not qualify.

Note: This is required because the code only excludes these types, there are many other types that have no such limitations.

Prescriptive water well pump VFDs:

Invoices must be dated on or after Jan. 1, 2016, to qualify for Water Well Pump VFD rebates.

- Installations must meet one of the equipment/situation combinations listed in the requirements rebate chart below to qualify as prescriptive.
- Installed on single stage or multi-stage centrifugal pump from 1 hp to 200 hp.

Requirements for water well pump VFD rebates		
For these systems	...controlled equipment must meet the following	...in these situations.
Water well pumps – New VFDs on previously throttled pumps or retrofit and replacing failed VFDs that were previously on throttled pumps	<ul style="list-style-type: none"> • Invoice date of January 1, 2016, or after • Existing throttling control • 20% minimum flow variation • Will operate at less than 100% speed during summer peak hours • Not used as a back-up 	<ul style="list-style-type: none"> • Municipal water supply • Golf course/landscape irrigation • Agricultural irrigation • Other applications could include; <ul style="list-style-type: none"> – Snow making when water is pumped from a well. – Lift stations that are pumping from a well. – Waste water pumping from a well. – Storm water pumping from a well.

The following information is required for the Water Well Pump VFDs. See the bottom of page 4 for full descriptions.

- Water well pump design flow
- Water well pump design head
- Static water level
- Maximum pumping water level
- Average pump flow

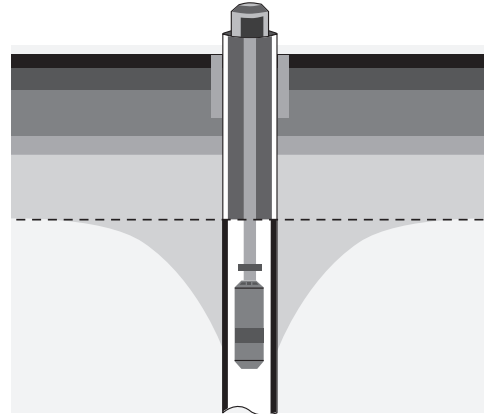

Custom drive rebate rules and requirements

We offer custom rebates for other types of variable speed drives that do not meet the requirements for our prescriptive program.

Custom Efficiency rebates require preapproval prior to purchase or installation of the equipment.

Examples of drive applications that do not qualify prescriptively, but may qualify for custom rebates include:

- VFDs placed on existing refrigeration compressors or air compressors.
- High static pressure installations such as drives on submersible pumps or any above ground pumps that operate systems with a high static dominated pressure level or poor sequencing, or that do not meet the Water Well Pump or HVAC VFD prescriptive rebate requirements.
- Non-fan, non-pump equipment such as presses, extruders, stirrers, conveyors, or vacuum pumps, process equipment or chillers.
- Positive displacement blowers or positive displacement pumps.
- Integrated VFD/Pump/Motor units.
- Multi-stage booster stations or pumps.
- A component of a larger system that does not have separate, itemized receipt/invoice for the drive.
- Any other situation that does not fit within the prescriptive rebates requirements listed in the charts to the left.

Visit xcelenergy.com/CustomEfficiency for application and program details.

Drives used in the following situations do not qualify for a rebate under the Xcel Energy Motor and Drive Efficiency rebate program.

- **Soft start**
- **Power correction capabilities**
- **Run less than 100 hours per year**

Rebate paperwork requirements

Please make sure that the supporting equipment information matches the rebate application claim.

- The customer invoice must show quantity, model number and hp.
- Maximum rebate is 60 percent of project cost.
- Customers must submit their rebate application claim for new variable speed drives within 24 months from the purchase date on the invoice.
- **Installation of the VFD must be complete before submitting rebate application.**

How to complete your application for variable speed drives

We offer prescriptive rebates for variable frequency drives (VFDs) or adjustable speed drives (ASDs) used on fan and pump equipment in HVAC and non-HVAC systems, pumping systems, cooling towers, industrial fans and water well pumps that are 1 hp–200 hp in size.

We offer custom rebates for drives for other equipment not mentioned above, or that are greater than 200 hp in size.

Directions for the equipment information tables

Rows: Complete the information on a separate row for each model/type of drive.

Columns: Review the heading descriptions below for instructions on what to include under each column.

End use function: Use the code from the chart at the bottom of page 5 that is closest to your end use type.

Manufacturer: Identify the manufacturer.

Model #: Make sure to use the manufacturer’s model number, not the part number. Also, make sure you don’t transpose or omit any numbers.

Drive HP: Please write the horsepower of the drive HP nameplate you have purchased and installed for the HVAC VFD, and non-HVAC specific end use or water well pump VFD.

RPM and enclosure: For invoices of January 1, 2017 or later: if you do not know the RPM (motor speed) or the motor enclosure that the VFD is controlling, you can use “UK” option to indicate “I don’t know” on the rebate application for the HVAC, non-HVAC and water well pump VFDs.

Motor HP: Please write the horsepower of the motor connected to the specific drive for the HVAC VFD, and non-HVAC or water well pump VFD.

Rebate HP:

For HVAC VFDs, non-HVAC and water well pump VFDs: The drive rebate is calculated using the lowest rating of either the drive nameplate hp or the motor nameplate hp for the specific line items’ end use.

For water well pump VFDs: The drive rebate is calculated based on the motor nameplate hp for the specific line items’ end use.

RPM: Please identify the revolution per min (RPM) of the motor that is controlled by the drive.

The following RPMs qualify under the prescriptive VFD rebate program:

- 8 pole = 900 RPM for invoices dated January 1, 2017 and later.
- 6 pole = 1200 RPM
- 4 pole = 1800 RPM
- 2 pole = 3600 RPM

The “I don’t know” option is only available for the following;

- RPMs – 900, 1200, 1800 and 3600. All other RPMS fall under the custom portion of the program.
- Enclosures – ODP and TEFC

Enclosure: Please identify whether the controlled motor is an open drip proof (ODP) or a totally enclosed fan cooled (TEFC) motor.

Quantity: For HVAC VFDs: Fill in the number of drives of this specific model for which you are seeking a rebate. For water well pump VFDs: Only one VFD is allowed per rebate line.

Rebate offer: The rebate offer amount is noted in the tiered chart on page 5.

Total Xcel Energy rebate: Multiply the drive quantity by the rebate offer (see page 5) to determine your total rebate.

Prescriptive Program Rebate Application
Application

Business Solutions Center 855.839.8862
Minnesota

Rebate amounts

Motor HP	Prescriptive rebate levels	Motor HP	Prescriptive rebate levels	Motor HP	Prescriptive rebate levels
1	\$400	15	\$1,250	75	\$5,000
1.5	\$400	20	\$1,600	100	\$6,000
2	\$400	25	\$2,000	125	\$7,000
3	\$400	30	\$2,400	150	\$7,000
5	\$600	40	\$3,000	200	\$8,000
7.5	\$750	50	\$3,500	Larger than 200	Requires custom evaluation and preapproval.
10	\$1,000	60	\$4,000		

For hp sizes that fall outside the hp chart, round down to the next hp value and use the corresponding rebate value.

Facility information

Please indicate the primary location where the motor will be installed.

Industrial/manufacture — Select only if the motor is used and installed at a facility that makes or produces a product.

Commercial — If selected, please identify which of the following best reflects the commercial building type where your motor is located. (Check one)

<input type="checkbox"/> Data center	<input type="checkbox"/> Healthcare/nursing/alternative care living facility	<input type="checkbox"/> Restaurant/fast food/casual/bar-and-grill-type facility
<input type="checkbox"/> Education – college/university	<input type="checkbox"/> Hospital	<input type="checkbox"/> Retail outlet/mall-type facility
<input type="checkbox"/> Education – K-12 school	<input type="checkbox"/> Hotel/motel/residence inn facility	<input type="checkbox"/> Warehouse/distribution center
<input type="checkbox"/> Grocery/superstore	<input type="checkbox"/> Office	

Section A – HVAC and non-HVAC VFDs

End use ¹	Manufacturer	Model #	Drive		Motor controller		Enclosure ²	Rebate offer		
			Qty	HP	HP	RPM ³		HP ⁴	\$ each	\$ total
1 ⁵							<input type="checkbox"/> ODP <input type="checkbox"/> TEFC <input type="checkbox"/> UK		\$	\$
2							<input type="checkbox"/> ODP <input type="checkbox"/> TEFC <input type="checkbox"/> UK		\$	\$
3							<input type="checkbox"/> ODP <input type="checkbox"/> TEFC <input type="checkbox"/> UK		\$	\$
Total – Section A rebate								\$		

¹For end use, please select one of the following two-letter codes and write it on your application:
 • Data center fan (DF) • Freezer case fan (FC) • Refrigerated case fan (RC) • All other fans (AF)
 • Data center pump (DP) • All other pumps (OP)

²Please mark invoices with row number for the corresponding VFD to ensure that the equipment description and rebate are matched to the correct invoice.
³For invoices of January 1, 2017 or later: if you do not know the RPM (motor speed) or the motor enclosure that the VFD is controlling, please use “UK” to indicate “I don’t know” on the rebate application for the HVAC, non-HVAC and water well pump VFDs.
⁴Rebate HP is the lesser of the drive HP or the motor HP

Section B – Water well pump VFDs

Manufacturer	Model #	Qty	VFD HP	HP	RPM ²	Enclosure ³	Pump VFD controlled				Motor application	Rebate \$ total
							Water well pump design flow (GPM)	Water well pump design head (ft)	Static water level (ft)	Maximum pumping water level (ft)		
1 ⁵						<input type="checkbox"/> ODP <input type="checkbox"/> TEFC <input type="checkbox"/> UK					Pump	\$
2						<input type="checkbox"/> ODP <input type="checkbox"/> TEFC <input type="checkbox"/> UK					Pump	
3						<input type="checkbox"/> ODP <input type="checkbox"/> TEFC <input type="checkbox"/> UK					Pump	
Total – Section B rebate											\$	
Total – Xcel Energy rebate (A+B)											\$	

¹Please mark invoices with row number for the corresponding VFD to ensure that the equipment description and rebate are matched to the correct invoice.
²If you do not know the motor RPM and Enclosure that’s controlled by the VFD, please use “UK” to indicate “I don’t know” for the description.

Page 5 of 6
17-03-428 | CRS 1982

For water well pump equipment table only:

Water well pump design flow: The design flow rate (GPM) for a water well pump

Water well pump design head: The design pressure head (ft) for a water well, or feet of head

Static water level: The average well depth (ft) for a water well pump

Average pump flow: The time weighted average flow rate (GPM) for a water well pump

Maximum pumping water level: The maximum well depth (ft) for a water well pump

Motor application: Pump

GPM: Gallons per minute • **ft:** Feet

Rebate amounts

Motor HP	Prescriptive rebate levels
1	\$400
1.5	\$400
2	\$400
3	\$400
5	\$600
7.5	\$750
10	\$1,000

Motor HP	Prescriptive rebate levels
15	\$1,250
20	\$1,600
25	\$2,000
30	\$2,400
40	\$3,000
50	\$3,500
60	\$4,000

Motor HP	Prescriptive rebate levels
75	\$5,000
100	\$6,000
125	\$7,000
150	\$7,000
200	\$8,000
Larger than 200	Requires custom evaluation and preapproval.

For hp sizes that fall outside the hp chart, round down to the next hp value and use the corresponding rebate value.

Facility information

Please indicate the primary location where the motor will be installed.

- Industrial/manufacture — Select only if the motor is used and installed at a facility that makes or produces a product.
- Commercial — If selected, please identify which of the following best reflects the commercial building type where your motor is located. (Check one)
 - Data center
 - Healthcare/nursing/alternative care living facility
 - Restaurant/fast food/casual/bar-and-grill-type facility
 - Education – college/university
 - Hospital
 - Retail outlet/mall-type facility
 - Education – K–12 school
 - Hotel/motel/residence inn facility
 - Warehouse/distribution center
 - Grocery/superstore
 - Office

Section A – HVAC and non-HVAC VFDs

	End use ¹	Manufacturer	Model #	Drive		Motor controller			Rebate offer		
				Qty.	HP	HP	RPM ³	Enclosure ³	HP ⁴	\$ each	\$ total
1 ²								<input type="checkbox"/> ODP <input type="checkbox"/> TEFC <input type="checkbox"/> UK		\$	\$
2								<input type="checkbox"/> ODP <input type="checkbox"/> TEFC <input type="checkbox"/> UK		\$	\$
3								<input type="checkbox"/> ODP <input type="checkbox"/> TEFC <input type="checkbox"/> UK		\$	\$
Total – Section A rebate										\$	

¹For end use, please select one of the following two-letter codes and write it on your application:
 • Data center fan (DF) • Freezer case fan (FC) • Refrigerated case fan (RC) • All other fans (AF)
 • Data center pump (DP) • All other pumps (OP)

²Please mark invoices with row number for the corresponding VFD to ensure that the equipment description and rebate are matched to the correct invoice.

³For invoices of January 1, 2017 or later: if you do not know the RPM (motor speed) or the motor enclosure that the VFD is controlling, please use "UK" to indicate "I don't know" on the rebate application for the HVAC, non-HVAC and water well pump VFDs.

⁴Rebate HP is the lesser of the drive HP or the motor HP

Please indicate the primary location where the VFD will be installed. (Check one)

- Municipal water supply
- Golf course/landscape irrigation
- Agricultural irrigation
- Other

Section B – Water well pump VFDs

	Manufacturer	Model #	Qty.	VFD HP	HP	RPM ²	Pump VFD controlled					Motor application	Rebate
							Enclosure ²	Water well pump design flow (GPM)	Water well pump design head (ft)	Static water level (ft)	Maximum pumping water level (ft)		Average pump flow (GPM)
1 ¹							<input type="checkbox"/> ODP <input type="checkbox"/> TEFC <input type="checkbox"/> UK					Pump	\$
2							<input type="checkbox"/> ODP <input type="checkbox"/> TEFC <input type="checkbox"/> UK					Pump	
3							<input type="checkbox"/> ODP <input type="checkbox"/> TEFC <input type="checkbox"/> UK					Pump	
Total – Section B rebate												\$	

¹Please mark invoices with row number for the corresponding VFD to ensure that the equipment description and rebate are matched to the correct invoice.

²If you do not know the motor RPM and Enclosure that's controlled by the VFD, please use "UK" to indicate "I don't know" for the description.

Total – Xcel Energy rebate (A+B)

\$

Sample invoice

ABC Sales/Installation and Service Company
17458 Middle of the City
Anywhere, USA 11111

Invoice # 12345
Date 1/1/16

Bill to:
 Customer A
 789 Anywhere St.
 Minneapolis, MN 55400-0000

Ship to:
 Customer A
 789 Anywhere St.
 Minneapolis, MN 55400-0000

PO No. Bill Terms
 2% 10 net 30

#1
 #2
 #3
 #4
 #5
 #6
 #7

Description/Part	Qty	Unit	Total
Remove existing panel and electrical items not in use. Install new six (6) new BCC MFZ08,3 hp VFD, pressure transducer, and sensor Job	6	\$400	\$2,400
Modifications to Building Controls including installing two (2) BCC 10 hp return fan VFD, Model JLZ462x Serial Number xc125fg. Engineering, programming, graphics, materials and installation	2	\$1,000	\$2,000
All BCC products: Three (3) – ALZ 1830, 40 hp	3	\$2,400	\$7,200
Two (2) AFZ 1640, 30 hp	2	\$2,400	\$4,800
Installation of EMS system, programming and integration of HVAC sequence of operations requirements	1	\$8,990	\$8,990
Install ABB ACS800-U1-0020-2, 20 hp VFD on water well pump #6	1	\$1,600	\$1,600
Install ABB ACS800-PC-0210-5, 200 hp VFD on water well pump #4	1	\$8,000	\$8,000
Thank you for your business. Please remit payment to: ABC Sales/Service		Total	\$34,990

Please write, on your invoice, the row numbers from the rebate application for the corresponding VFD. The numbers written on this sample invoice correspond to information provided on rows: 1, 2, 3, 4, 6 and 7 of the rebate application example shown on page 4.